

Dept.	Technical reference	Created by	Approved by
		Document type	Document status
		Title	DWG No.
		Ccannon explosion drawing	
Rev.	Date of issue	Sheet	
		1/3	

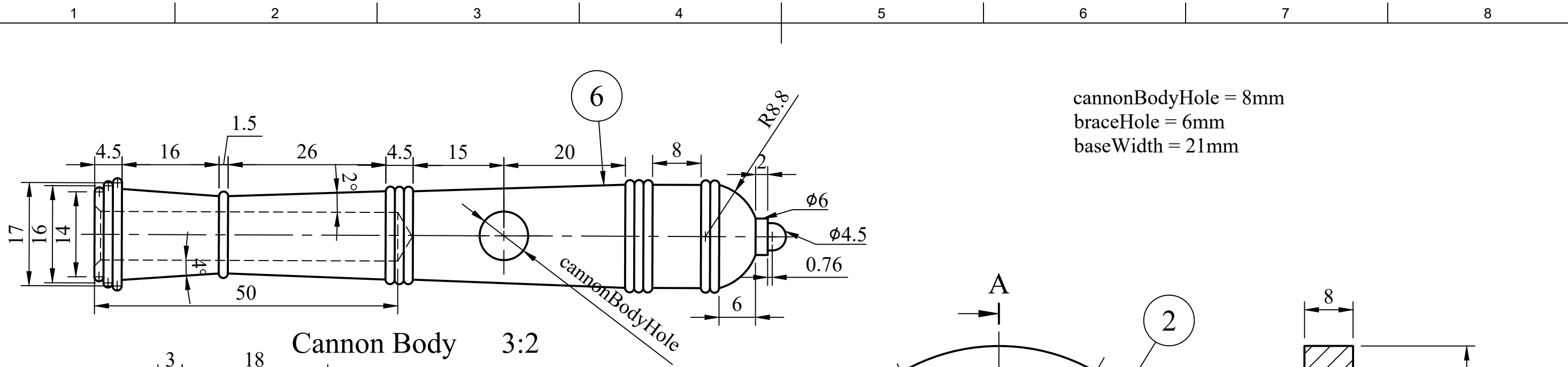

Cannon Body 3:2

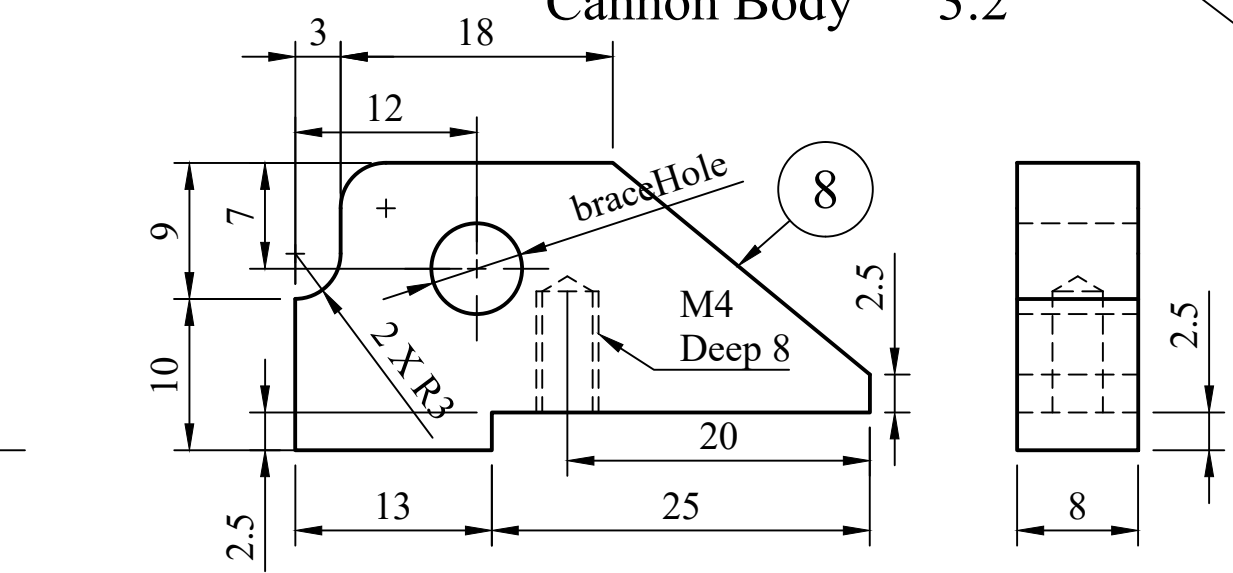

Brace 2:1

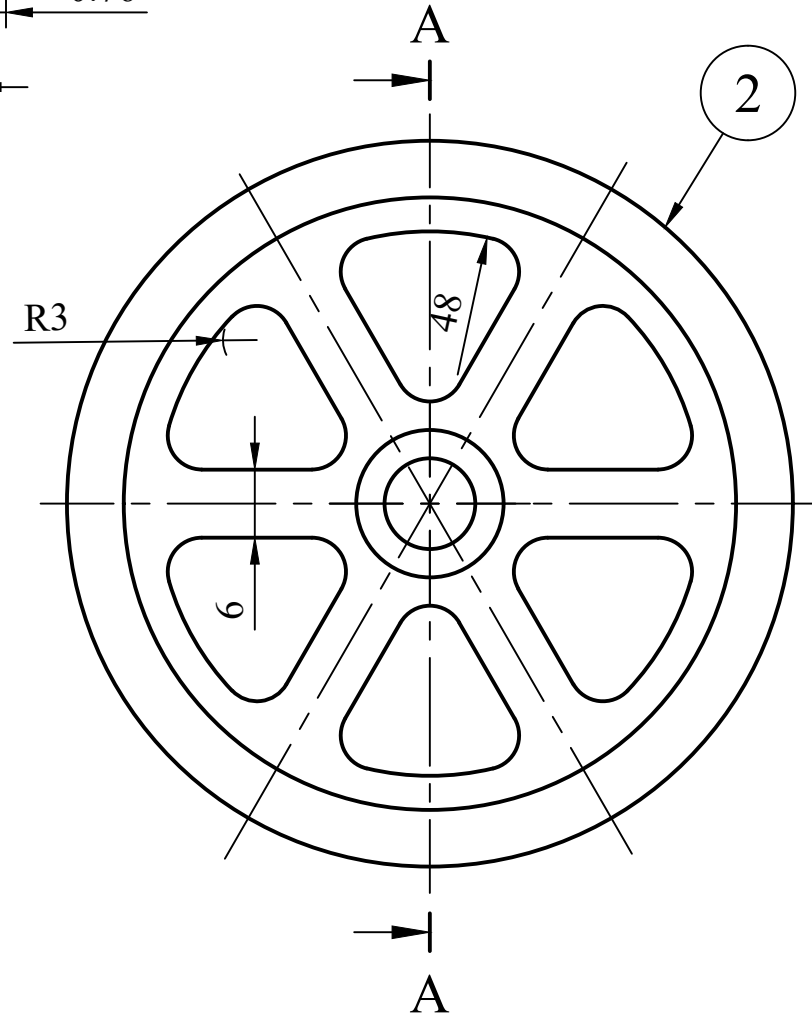

Wheel 3:2

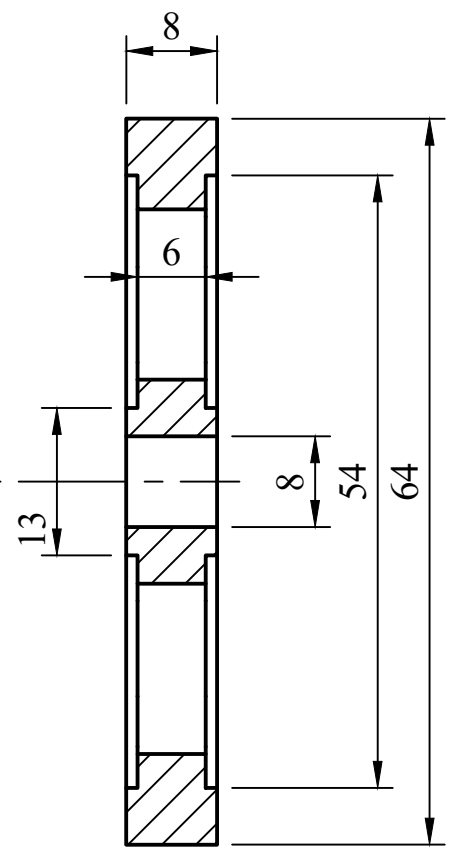

Section A-A

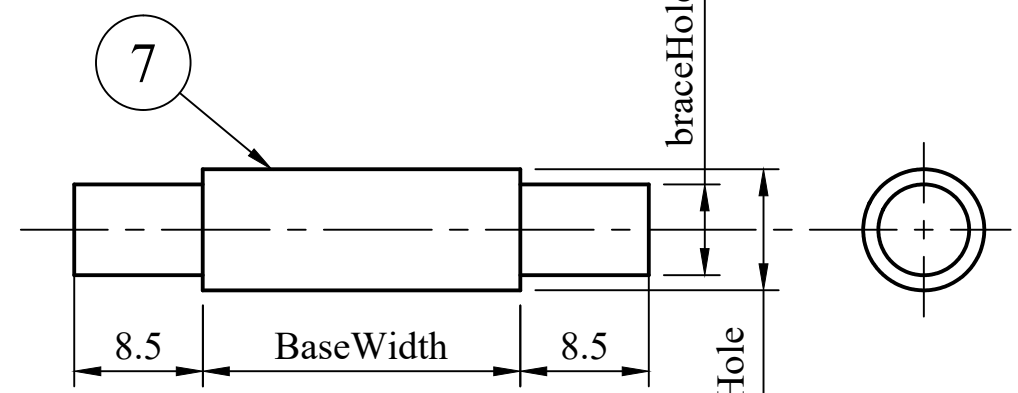

Pin 2:1

Dept.	Technical reference	Created by	Approved by
		Document type	Document status
		Title	DWG No.
		Cannon	
Rev.	Date of issue	Sheet	2/3

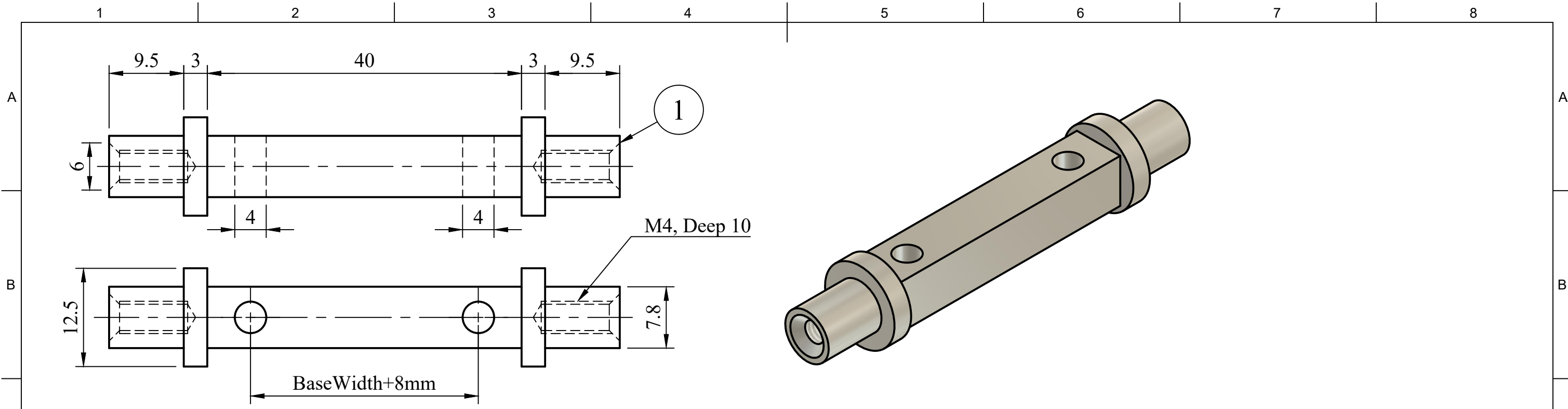

Spinder 2:1

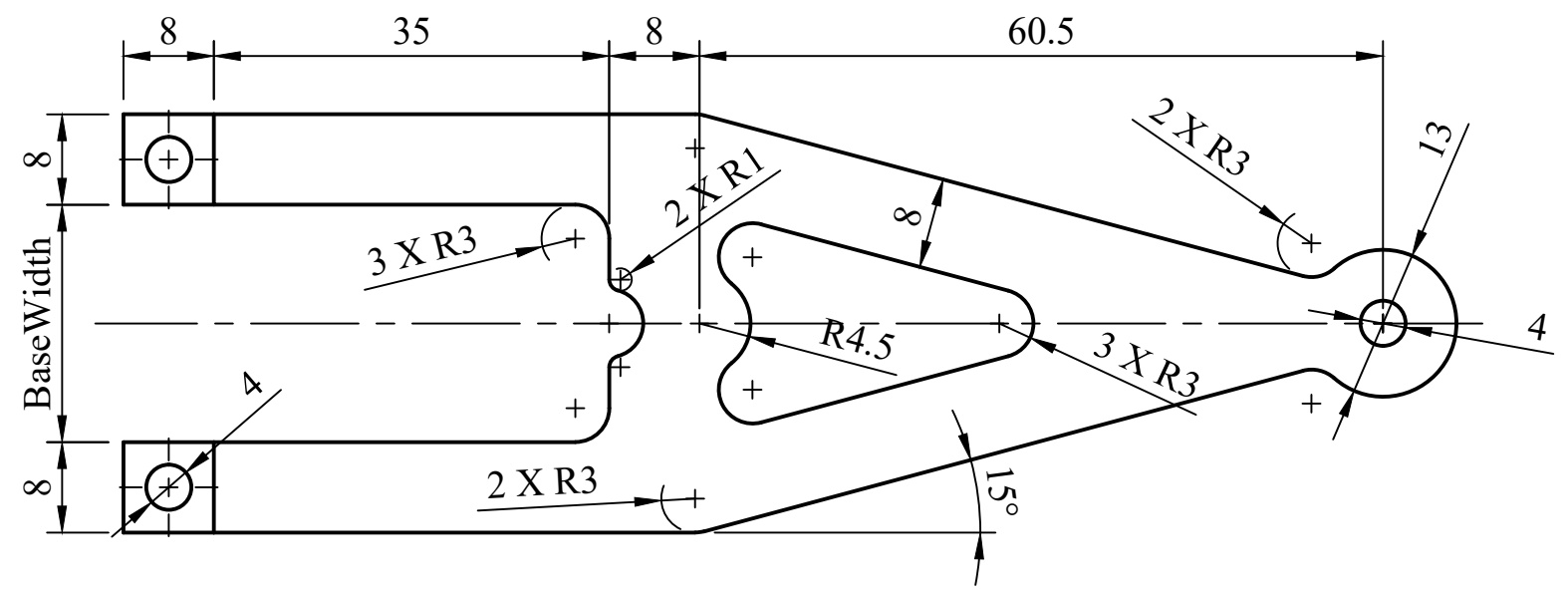

Base 3:2

Dept.	Technical reference	Created by	Approved by
		Document type	Document status
		Title	DWG No.
		Cannon	
Rev.	Date of issue	Sheet	3/3